

# Model Railway Level Crossing Lights

A magnet under the train operates reed switches positioned on the track. The trigger reed switch starts the sequence by switching on the amber light, a few seconds later the two red lights start to flash. When the train has passed the level crossing it operates the cancel reed switch which switches off the lights until the next train arrives. There is a PCB pattern for this project, but you may prefer to build it on stripboard using the layout provided on this webpage: [www.newrailwaymodellers.co.uk/railway\\_crossing.htm](http://www.newrailwaymodellers.co.uk/railway_crossing.htm)

## Parts Required

- resistors: 680  $\times$ 3, 1k  $\times$ 3, 33k, 47k, 82k, 270k
- capacitors: 0.1 $\mu$ F  $\times$ 3, 10 $\mu$ F radial  $\times$ 2
- 555 timer IC  $\times$ 3
- 8-pin DIL socket for IC  $\times$ 3
- miniature magnet(s) - each locomotive needs one
- printed circuit board (PCB) - pattern given below
- red LED (3mm best)  $\times$ 2
- amber or yellow LED (3mm)
- on/off switch
- battery clip
- reed switch  $\times$ 2

## PCB component layout

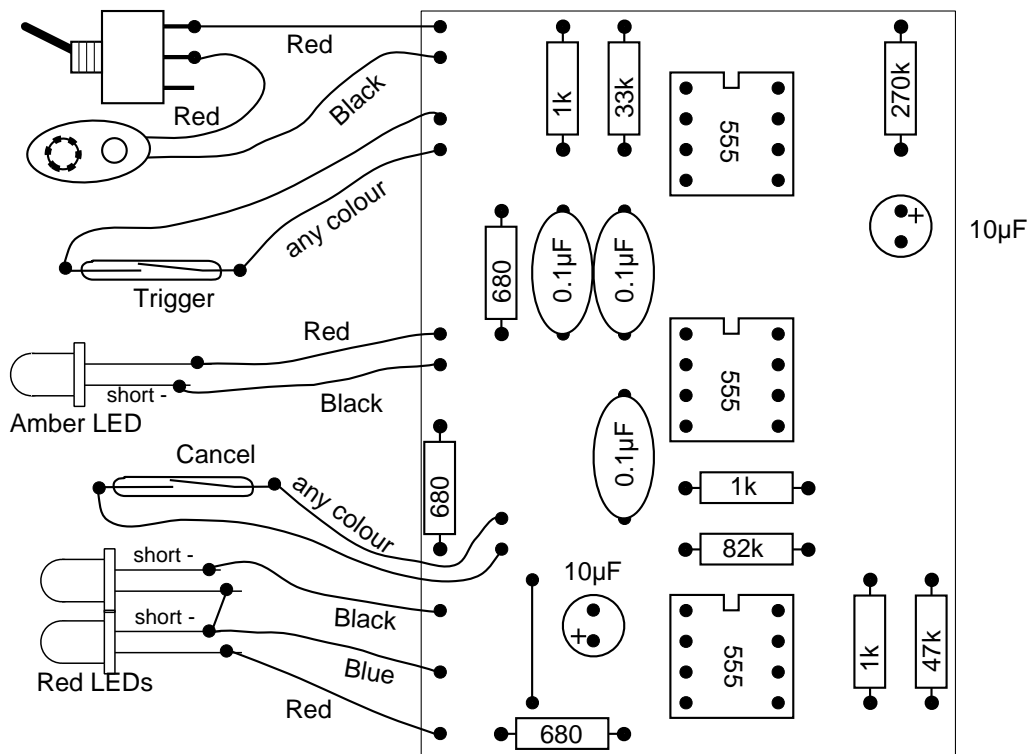

## Track connections



The reed switches can be held in place between the rails with a small piece of blu tac. Each locomotive will need a miniature magnet glued to its underside, test first with blu tac, then use superglue.

## Circuit diagram

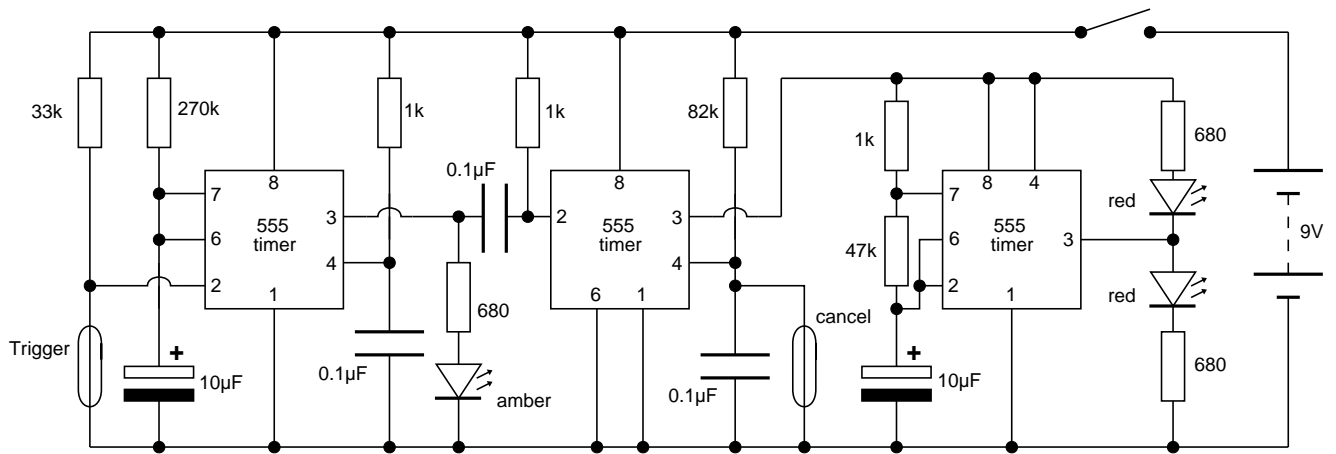

## PCB copper track pattern

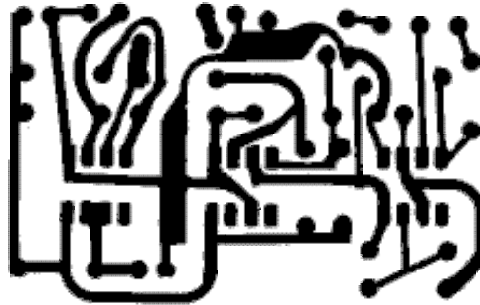

PCB for Level Crossing Lights  
(view from copper track side)